



# AVENTURA 500

## EURO 5



**OWNER'S MANUAL**





**RIEJU S.A.** would like to thank you for your trust in our company and congratulate you on an excellent choice.

The **AVENTURA 500 Euro 5** model is the result of **RIEJU'S** extensive experience in developing high-performance vehicles.

The purpose of this Owner's Manual is to set forth how to use and maintain your vehicle. We ask that you carefully read the instructions and the information provided as follows.

Please remember that the vehicle's lifespan depends on how you use and maintain it. Keeping it in perfect operating condition reduces the cost of repairs.

Please consider this manual an integral part of the vehicle. It must remain with its basic equipment, even in the event of a change in ownership.

For any issues, please see your **RIEJU** dealer, who will be delighted to serve you, or visit **[www.riejumoto.es](http://www.riejumoto.es)**

Remember that for your vehicle to operate properly, you must always request original replacements.



## CONTENTS

Vehicle description .....	6	Adjustment of shift pedal.....	49
Vehicle registration .....	7	Adjustment of rear brake pedal .....	50
Vehicle delivery .....	8	Adjustment of throttle control handle .....	51
Inspection Prior to delivery .....	9	Adjustment of clutch handle .....	52
Technical info .....	12	Adjustment of rear shock absorber .....	53
Location of serial numbers .....	14	Spring preload adjustment .....	53
Chassis identification number .....	14	Compression adjustment .....	54
Engine identification number .....	14	Rebound adjustment .....	54
Builder label .....	15	Headlamp light height adjustment .....	55
Main vehicle elements .....	16	Running in of new vehicle .....	56
Ignition switch .....	21	Engine running in .....	56
Meter and indicators .....	23	Tyre running in .....	57
Operating instructions for instruments .....	24	Running in of braking system .....	57
Indicator description .....	27	Vehicle driving .....	58
Left clutch handle combination switch .....	37	Pre driving inspection .....	58
Right brake handle combination switch .....	37	Engine start .....	62
Left and right handle control .....	38	Road driving .....	64
Fuel tank selection .....	43	Variable speed device .....	66
Adjustment before driving .....	46	Braking and parking .....	67
Adjustment of steering handle.....	46	Fuel .....	68
Mirror adjustment.....	47	Fuel evaporation .....	69
Adjustment of front brake handle .....	48	Catalyst .....	71



Troubleshooting .....	72	Vehicle storage .....	108
Inspection and maintenance .....	74	How to reactivate the vehicle .....	110
Daily inspection .....	74	Vehicle protection .....	111
Battery maintenance .....	75	Vehicle cleaning .....	111
Battery charging .....	76	Modifications and accessoires .....	113
Disassembly and assembly of battery .....	78	Maintenance table .....	115
Maintenance of air filter .....	80	Warranty .....	117
Engine oil maintenance .....	81		
Replace the oil filter element .....	84		
Coolant maintenance and inspection .....	87		
Coolant replacement .....	89		
Brake fluid maintenance .....	91		
Inspection of brake fluid .....	92		
Drive chain maintenance .....	94		
Adjustment of drive chain .....	96		
Tire maintenance .....	97		
Inspection of tire wear limit .....	99		
Fuse box .....	102		
Brake pad .....	104		
Oil filter replacement .....	106		
Replacement of light signal .....	107		
Storage and cleaning of vehicles .....	108		



## **VEHICLE DESCRIPTION**

This motorcycle has a four-stroke single-cylinder engine with water cooling. Its cubic capacity is 471 cubic centimetres, with a 67-mm diameter piston with 66,8 mm movement.

It is turned on with an electric wheel and 140 W AC spool.

Steel and friction multi-plate clutch with constant pressure springs, immersed in oil bath.

The motor is anchored to a highly resistant central chassis, with cone roller bearings.

The front suspension is a hydraulic fork with 43-mm diameter bars. Rear suspension is a hydraulic mechanical shock absorber that provides gentle operation.

The front and rear brakes are stainless steel disc brakes. The front measures 320 mm and the rear 260 mm.



## VEHICLE REGISTRATION

Please make a note of the chassis and engine serial numbers, which will help you for all purposes (certificate of characteristics, insurance, registration, etc.).

These numbers will be useful for you for any suggestions or complaints, as well as to order replacement parts.

Chassis serial number (p.14)

Engine serial number (p.14)

Dealer seal



## **VEHICLE DELIVERY (complete upon first delivery)**

- USER MANUAL**  
Explain the importance of reading it and understanding all the information. Highlight the sections on safety and maintenance practises.
- WARRANTY REGISTRATION CARD**  
Complete the necessary information and provide the customer with a copy.
- HANDLING**  
Explain how to properly handle the vehicle.
- WARNINGS**  
Explain the importance of the warnings to guarantee a long “life” for the vehicle.
- KEYS**  
Deliver the complete set. Advise them to make a backup set.
- FIRST INSPECTION**  
Explain that an inspection after 500 km is important.
- PERIODICAL MAINTENANCE**  
Explain the need for periodical maintenance and state that failure to comply with guidelines for check-up and visiting the shop is grounds for “Loss of Vehicle Warranty”.





**INSPECTION PRIOR TO DELIVERY (Adjustments)**

**General appearance** .....  .....

**Engine**

- Engine oil level .....  .....

- Emptying the carburettor float chamber .....  .....

**Chassis**

- No fuel leaks in: Tank output, fuel tap, and supply lines .....  .....

- Front and rear brake - Drain, if necessary .....  .....

- Coolant level, if applicable .....  .....

- Front, rear mudguard and attachment elements .....  .....

- Wiring of electrical installation around the steering column .....  .....

- Alignment of front, rear wheels, and tightening torque of wheel axles .....  .....

- Spokes of front and rear wheels .....  .....

- Tyre pressure .....  .....

- Chain tension .....  .....

**Checking the equipment**

- Accelerator works and has free play. Adjust if necessary .....  .....

- Degrease both brake discs .....  .....

- Battery charged and terminals greased .....  .....

- Block steering or anti-theft block .....  .....



- Electric start-up (depending on model) engine operation .....
- General condition of front and rear suspension .....
- Clutch cable properly adjusted .....
- Operation of fuel cap closure .....
- General inspection of nuts and screws: Callipers/discs, transmission/pinions, wheel nuts, tilt, engine mounts, exhaust system, shock absorber, gear selector, brake pedal/levers, manifold nuts, etc. ....

**Fuel tank**

- Check that the tank is not in contact with the frame .....

**Driving components**

- The digital instrument dashboard checks itself when the ignition is turned on (depending on the model) .....
- Adjusting the headlight height .....
- Brake light when pressing brake levers LH and RH .....
- Front, rear blinkers and mounting clips .....
- Horn operation .....

**ON-ROAD TEST, at least 10 km**

- Engine and gearbox operation .....
- Grip on road and suspensions .....
- No abnormal sounds .....



**AFTER ON-ROAD TEST**

- Coolant leaks .....  .....
- Fuel system, including hoses, clips, and all associated parts where leaks may appear .....  .....
- Check breakdown codes with diagnostic tool and delete them if applicable (depending on the model) .....  .....

**CHECKING FINAL APPEARANCE** .....  .....

Date

Manufacturer signature



## TECHNICAL INFO

GENERAL INFORMATION	
Fuel	Unleaded petrol E5
Oil filter	Paper
Oil pump	Mechanical
Water pump	Single-suction centrifugal pump
Spark plug - Spark area	NGK ECPR8EA-9

SIZES	
Distance between axles	1.470 mm
Length	2.220 mm
Height	1.480 mm
Width	930 mm
Saddle height	835 mm
Dry weight	190 Kg
Fuel tank (1)	20 L
Fuel tank (2)	19 L



<b>CHASSIS</b>	
Chassis	Steel perimetral
Front suspension	Fork Ø43mm
Rear suspension	Mono-shock shock absorber
Front tyre	90/90 R21"
Rear tyre	150/70 R18"
Front brake	Ø320 mm disc
Rear brake	Ø260 mm mm disc

<b>ENGINE</b>	
Type	4t twin cylinder – 471 c.c. – 4 Injection valves x cylinder
Diameter x Span	67x66,8 mm
Shift	6-Speed. Foot shifter
Cooling	Water
Start-up	Electric
Lubrication	Flooded body
Oil type	10W40 GRO
Amount of oil	
Without replacing oil filter ensemble	2.7 litres
With replacement of the oil filter	3.1 litres



## LOCATION OF SERIAL NUMBERS

### Chassis identification number

This is the number (1) that is die-cut on the right of the steering tube.



### Engine identification number

This is the number (1) that is marked on the bottom of the engine's left crankcase half.

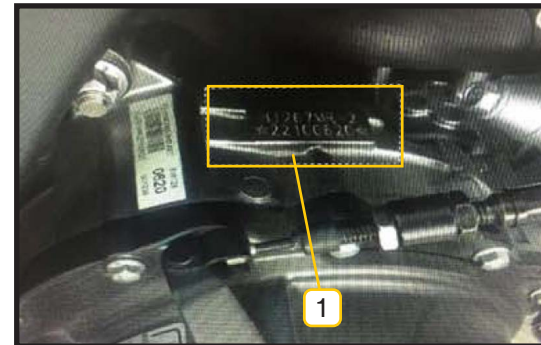



### Builder label

Your **RIEJU** has an identification plate (1) with details on: manufacturer, frame number, approval number, and sound emissions level.

The frame number is also die-cut on the right side of the steering tube.

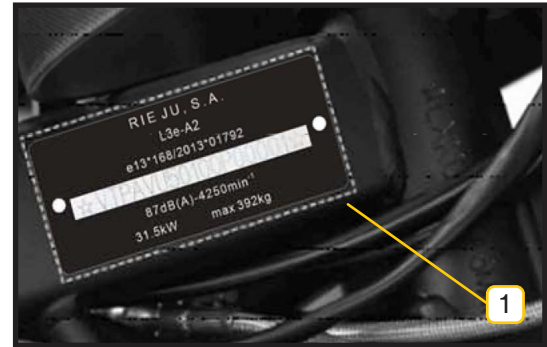



## MAIN VEHICLE ELEMENTS



1. Wind deflector
2. Mirror
3. Brake/clutch handle guard
4. Turn lights
5. Headlamp
6. Bumper\*
7. Water tank filler
8. Front shock absorber
9. Front shock absorber trim panel



\*Bumper (6) is not standard for all vehicles.

\*Due to the continuous R & D and updating of the company's products, the appearance pictures quoted in the manual may be inconsistent with the appearance of the vehicle you purchased. Please take the actual appearance of the vehicle as the standard.



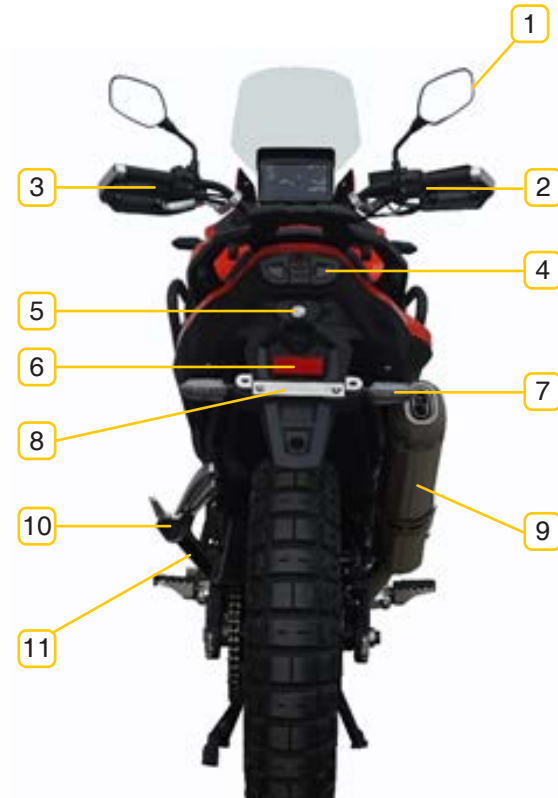

1. Rear view mirror
2. Front brake handle
3. Clutch handle
4. Tail light / stop light
5. Seat cushion lock
6. Rear reflector
7. Rear turn signal lamp
8. License plate bracket
9. Muffler
10. Rear footrest
11. Side stand



1. Reflector (left)
2. Front brake disc (left)
3. Front brake pump (left)
4. Shift arm
5. Chain slack adjuster (left)
6. Rear footrest
7. Rear shock absorber preload adjustment





1. Secondary gas tank filler
2. Front/rear Fuel switch
3. Front reflector (right)
4. Front brake disc (right side)
5. Front brake pump (right side)
6. Rear brake pedal
7. Rear brake hydraulic cup
8. Chain adjuster (right)
9. Rear brake disc





1. Whole vehicle fuse box
2. Fault detection interface
3. Relay group
4. ECU
5. Battery
6. Battery negative connector
7. Air filter easy access.
8. Battery positive connector

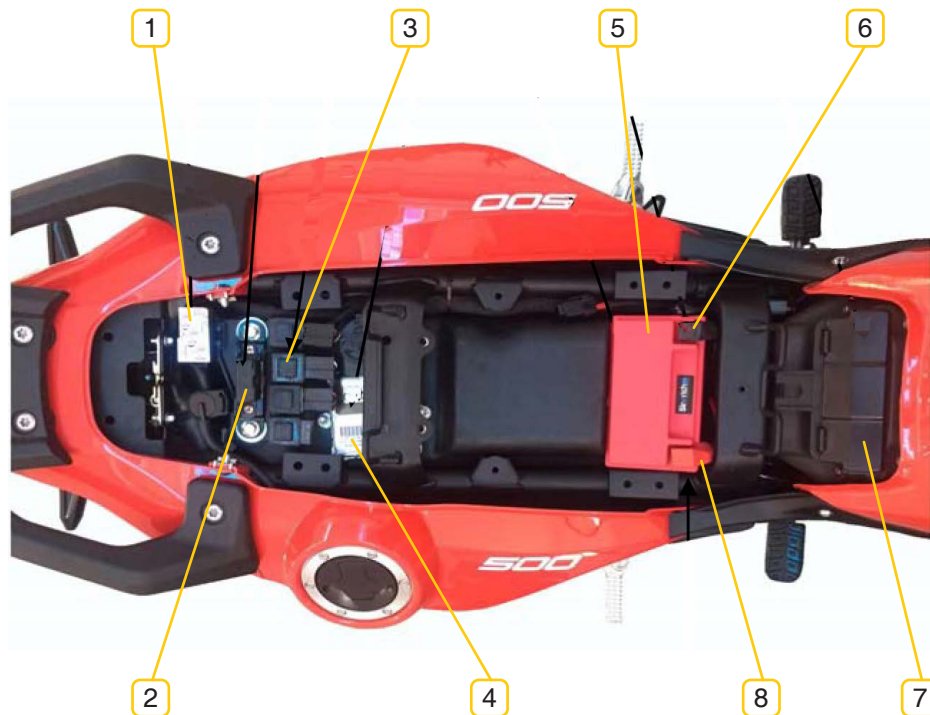



## IGNITION SWITCH

The ignition switch of the vehicle is located at the front end of the fuel tank and below the instrument. The ignition switch and direction lock are integrated.

This vehicle is equipped with two keys, one of which should be kept properly for standby.



Ignition switch lock, direction lock, cushion lock and fuel tank lock all share the same key.

The ignition switch has three positions:

- The position ignition circuit is connected, the ignition can be started at any time, and all functional circuits of the whole vehicle are connected. The key cannot be removed in this position.
- ⊗ If the ignition circuit is disconnected and the ignition cannot be started, the key can be pulled out at this position.
- 🔒 Position is the locking steering handle. First turn the





steering handle to the leftmost position, press the key at “” position, and then turn counterclockwise to “” position. In this position, the key can be pulled out, the ignition circuit is disconnected, and the ignition cannot be started.



**CAUTION:** Although this series of vehicles are equipped with side support system, for parking stability, please try to turn the steering handle to the leftmost position instead of the rightmost position when locking the steering handle.

Do not turn the ignition switch key to the “” position during driving, otherwise the motorcycle will lose control.



## METER AND INDICATORS

1. Left turn indicator
2. Time
3. ABS indicator
4. Oil alarm lamp
5. Water temperature alarma lamp
6. High beam indicator
7. Fuel warning lamp
8. Engine fault warning lamp
9. Battery alarm lamp
10. Maintenance indicator
11. Bluetooth indicator
12. Right turn indicator
13. Wifi indicator
14. Main oil tank level
15. Secondary oil tank level
16. Main oil tank warning lamp
17. Secondary oil tank warning lamp
18. RPM display
19. Gear display
20. Current vehicle speed display
21. ODO
22. TRIP1 or 2
23. RPM display
24. Temperature engine

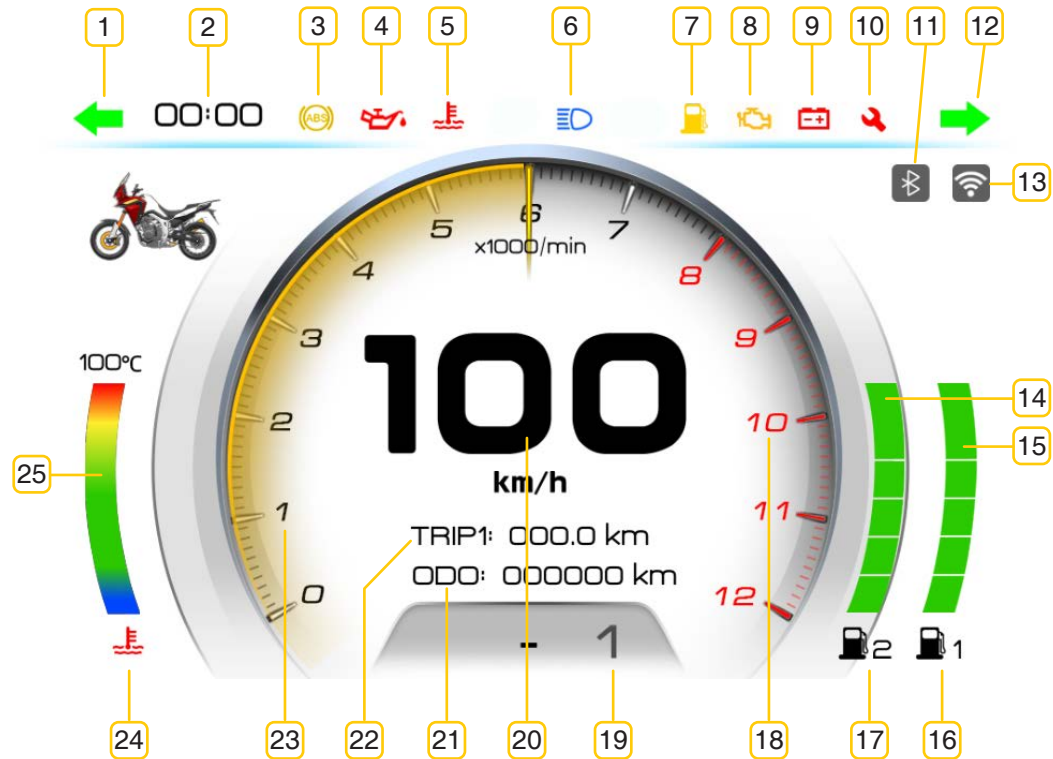



## Operating instructions for instruments

Press the SET button on the left handle (figure 2) to enter the configuration menu (figure 3).

Then use the MODE button to navigate down the menu to the desired mode and press SET to access that option.

You can go back to the main display by choosing the QUIT option or by waiting a few seconds without pressing any of the two buttons.

- **Road mode:** Use MODE to switch between ON and OFF and SET to select the desired option. ON activates the Off-Road conduction mode, and OFF deactivates it. When it is on, an Off-Road indicator will appear in the display.
- **Time:** This option allows you to change the instrument's time. Use SET to change the selected digit and MODE to switch to the next digit. When done, select RETURN with MODE and press SET.



Fig. 2



Fig. 3





- **Bluetooth:** Select this option to choose whether you want your motorbike to be visible to other Bluetooth devices or not. Press SET to change between ON and OFF. You can also view your motorbike's Bluetooth name here. When done, use MODE to select RETURN and press SET.
- **Phone link:** Press SET to Start Interconnection and follow the instructions. You will need to download the Carbit Ride APP by scanning the QR code or directly from your phone's app store. With the app opened, press the icon on the upper right corner of the screen and scan the QR code to link your phone with the motorbike.

Once your phone is linked, the Wi-Fi indicator will appear in the motorbike's display, indicating that it's connected to the network through your phone, but not necessarily to a Wi-Fi.

If you allow access to your location, the navigation map will appear in the instrument.



**CAUTION:** Remember to always pay attention while driving. Avoid distractions and do not use your mobile phone while driving.



- **Unit:** Use MODE to switch between METRIC (km/h) and IMPERIAL (MPH) unit systems and use SET to select the desired option.
- **Language:** Use MODE to switch between SPANISH and ENGLISH and use SET to select the desired option.
- **Ver display:** Select this option to view the software and MCU versions.
- **Quit:** Select this option to quit the configuration menu and return to the display.

Night mode (figure 4): When entering a dark location, such as a tunnel, the instrument automatically enters night mode and dims its brightness.





Fig. 4



## Indicator description



### Left turn indicator

When the steering switch of the brake assembly is pushed to the “ “ position on the left, the “ “ indicator lights of the instrument light up and flash.





**CAUTION:** When the steering light of the vehicle is damaged or does not light up due to other reasons, the flashing frequency of the indicator “ “ will be faster than that in normal use, prompting to check the steering light fault.





### ABS fault indicator

When the ABS system of the vehicle fails or is turned off, the indicator light “ “ on the instrument flashes or is always on.

When the ignition switch key is turned to the “ “ position, the indicator light “ “ is on, and the indicator light “ “ should be off immediately after the engine is started.





### CAUTION:

- If the indicator light “ “ is always on or flashing after the engine is started, abnormal braking or even locking of wheels may occur if you continue to use the vehicle at this time. Please do not continue to drive the vehicle.
- If the indicator light “ “ is always on or flashing during driving, please stop using the vehicle immediately and consult the authorized RIEJU dealer for troubleshooting as soon as possible.



## Oil pressure indicator

When the oil pressure is lower than the normal range, the indicator light “” is on.

When the ignition switch key is turned to “” position, the indicator light “” will be on; After the vehicle completes the self-test, the indicator light “” shall go out immediately.

This warning light is lit to warn that the pressure of the lubrication system is too low. At this time, stop the engine immediately and shut down the engine.

The only way to check whether the lubricating oil level is correct is to confirm through the oil window.

One reason why the oil warning signal light is on is that the oil level is too low. Check the engine oil level. If the oil level is too low, add oil.

If the engine oil warning light is always on when the engine oil level is determined to be correct, please do not drive any more, and please go to the authorized **RIEJU** dealer for troubleshooting as soon as possible.





### CAUTION:

- The oil pressure indicator “” does not indicate the oil level, but indicates that the oil pressure is abnormal, so you should regularly check whether the oil level is normal.
- The only way to check whether the oil level is normal is to check the position of the oil level in the oil window.



### High beam indicator

When the headlamp switch of the left brake assembly is pushed to the “” position, the indicator light “” will be on.

When the overtaking light button of the left brake handle assembly is pressed, the indicator light “” will be on until you release it





### CAUTION:

- Please do not use high beam on urban roads with illuminated roads.
- Please turn off the high beam when following.
- Please turn off the high beam when meeting.



### Coolant temperature indicator

When the engine coolant temperature is too high, the indicator light “” is on.

When the coolant temperature indicator “” is on, stop at a safe place on the road and turn off the engine until the indicator goes out.



If the coolant level is too low, replenish the coolant.

If the radiator fan does not work when the coolant temperature indicator “” is on, please shut down the engine and go to the authorized **RIEJU** dealer for troubleshooting as soon as possible.

If the coolant is insufficient or the radiator surface is seriously blocked by sediment, the following temporary treatment methods are recommended:





1. Reduce the load of the vehicle to reduce the generation of engine heat.
2. In case of traffic congestion, try to keep the engine at idle speed and do not turn the throttle to avoid the temperature rising due to the increase of speed.
3. If the above operation still can not effectively cool down, please shut down the engine and go to the authorized **RIEJU** dealer for troubleshooting as soon as possible.

**CAUTION:**

- If the coolant temperature indicator “” is on, please check whether the radiator grid is blocked by sediment dust, which will greatly reduce the heat dissipation efficiency of the radiator.



### Engine fault warning lamp

When the electronic fuel injection system of the vehicle fails, the warning lamp “” will be on. When the ignition switch key is turned to “” position, the indicator light “” will be on during vehicle self-test; When the vehicle completes the self-test, the indicator light “” goes out immediately.



### CAUTION:

- If the engine fault light is on, please stop the engine and take the motorcycle to the authorized **RIEJU** dealer for troubleshooting as soon as possible.





### Maintenance light

The maintenance indicator lights up every 8,000 km after the first service to remind you to carry out vehicle maintenance (the first service is at 500 km).



### Right turn signal indicator

When the steering switch of the brake assembly is pushed to the right, the indicator light “” is on.



### CAUTION:

- When the steering light of the vehicle is damaged or does not light up due to other reasons, the flashing frequency of the indicator “” will be faster than that in normal use, prompting to check the steering light fault.



### Front tank warning indicator

When the fuel in the main tank is insufficient, “” icon is red and flashes. At this time, please use the fuel tank switch on the right side of the instrument to switch to the rear tank or add fuel.



### Rear tank warning indicator light

When the auxiliary fuel tank is short of fuel, “” icon is red and flashes. At this time, please use the fuel tank switch on the right side of the instrument to switch to the main fuel tank or add fuel.



### CAUTION:

- Please use unleaded petrol only. We recommend using E5 petrol, although the engine can also handle E10 petrol without any issues. Using any other type of petrol or diesel may cause irreparable damage to the engine.
- Insufficient fuel will cause the engine to fail to ignite. If the engine fails to ignite due to insufficient fuel, hastily continuing ignition may lead to irreparable losses.
- Please do not use up the fuel in the tank.
- The fuel will corrode the paint surface and make it fade and ugly. If fuel oil is attached to the painted surface, it shall be wiped clean immediately.
- The fuel will expand at high temperature. Overfilling the fuel tank will lead to excessive internal pressure, resulting in tank deformation or fuel overflow.
- Turn off the engine when filling fuel, and do not approach fireworks or heat sources.



### **RPM speed display**

Engine speed, unit: R / min (revolutions / minute) - the current number of revolutions per minute of the engine crankshaft.).

The speed red band indicates that the engine has reached the maximum speed. If it runs at this speed, it will inevitably shorten the service life of the engine.

### **Gear display**

Displays the current gear position of the engine and "N" in neutral also displays the previous and next gears of the current gear in a lighter color.

### **Speed display**

Displays the current driving speed of the vehicle.



### **Coolant temperature bar**

Displays the current coolant temperature range. If the coolant temperature remains in the red position, please stop immediately for inspection. If the coolant temperature indicator “” is on at this time, please shut down the engine and go to the authorized **RIEJU** dealer for troubleshooting as soon as possible.

### **Mileage display**

The instrument provides total mileage (ODO) and short mileage (TRIP1 / TRIP2) display.



#### **CAUTION:**

When washing the car, do not wash the instrument with high-pressure water gun to avoid damaging the instrument.



### Left clutch handle combination switch

1. Clutch handle
2. Overtaking light button
3. Set button
4. Select button
5. Headlamp dimmer switch
6. Turn signal switch
7. Horn

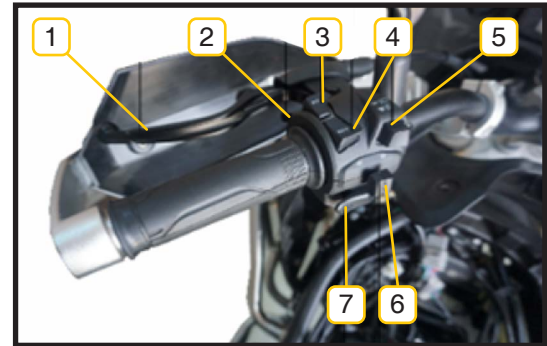

### Right brake handle combination switch

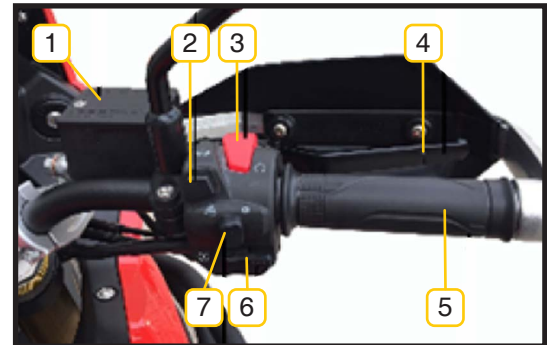

1. Front brake upper hydraulic oil cup
2. ABS switch
3. Engine shutdown switch
4. Front brake handle
5. Throttle knob
6. Ignition switch
7. Emergency light switch





## Left and right handle control

### ABS switch

With the motorcycle stationary press and hold the ABS switch “” for 4 seconds to turn off the front and rear ABS of the motorcycle. At this time, the “” indicator of the instrument is always on; Press and hold again for 4 seconds to turn on the vehicle ABS.

After turning off the motorcycle, either by using the shutdown switch or the ignition key, the ABS will perform a new self-assessment and will reconnect, causing the “” indicator on the instrument panel to disappear.





**CAUTION:** During driving, it is strongly recommended that you do not turn off the vehicle ABS system to avoid accidents or personal injury during driving.

Disconnecting the ABS is not allowed on public roads, it is intended for offroad use and experienced riders.

### Engine stop

When the flameout switch is pressed to “”, the engine starting circuit is disconnected and the engine cannot be started.

When the flameout switch is pressed to “”, the engine starting circuit is connected and the engine can start normally.

When the engine is started and the flameout switch is pressed to “”, the engine will shut down immediately. The flameout switch is the fastest and easiest way to turn off the engine.



**CAUTION:** If the flameout switch is pressed to “” during vehicle driving, the rear wheels may be suddenly locked and the vehicle may fall. Please do not operate the flameout switch button during driving.



### Front brake handle

Hold the brake handle tightly, the front wheel brakes, and the rear brake lamp lights up at the same time.

### Throttle knob



Rotate the handle to the driver's side to increase the throttle; Conversely, reduce the throttle.

### Ignition switch

When the "  " button is pressed, the engine start circuit is turned on and starts.

### Emergency light switch

### Overtaking light button "PASS"

When the "PASS" button is pressed, the high beam lamp will turn on and the "  " high beam indicator lamp on the instrument will also turn on. After releasing the button, the high beam lamp will turn off and the "  " high beam indicator lamp on the instrument will also turn off.

### Headlamp dimmer switch

When the headlamp dimmer switch is pressed to "  ", the high beam lamp is on, and the high beam indicator lamp "  " on the instrument is also on.





**CAUTION:**



- Please do not use high beam on urban roads with illuminated roads.
- Please turn off the high beam when following.
- Please turn off the high beam when meeting.





### Turn signal switch



When the steering switch of the left clutch assembly is pushed to the left “”, the front and rear steering lamps on the left side of the vehicle will be on at the same time, and the left steering indicator lamp “” of the instrument will also be on and flash.

When the steering switch of the left clutch assembly is pushed to “” on the right side, the front and rear steering lamps on the right side of the vehicle will light up at the same time, and the right steering indicator lamp “” of the instrument will also light up and flash.

When the steering switch of the left clutch assembly is pressed inward, the steering light goes out and the steering indicator light on the instrument goes out at the same time.





### CAUTION:

- When the turn signal on one side of the vehicle is damaged or the turn signal is not on due to other reasons, the lashing frequency of the “” or “” turn signal on the corresponding side of the instrument will be faster than that in normal use, prompting you to check whether the turn signal on the corresponding side is faulty.



### Warning light button

When the “” button is pressed, all steering lamps and “” and “” steering indicators on the instrument light up and flash at the same time.

Please use warning lights to warn other vehicles in case of emergency stop or traffic accident or failure of your vehicle.



### Horn button

When the “” button is pressed, the vehicle horn sounds.



## FUEL TANK SELECTION

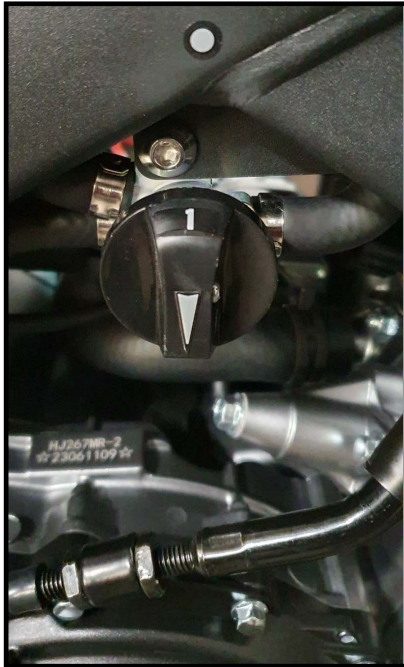

FRONT TANK



REAR TANK



## Change to FRONT TANK (1)

Step 1



Step 2



**CAUTION:** Before starting the motorcycle, ensure that the fuel valve position matches the switch's position. **Starting the motorcycle with the valve in a position other than the switch's position can cause serious damage to the motorcycle.**

For front tank (1), in step 1 the button must be in the outer position, and the fuel switch must show the number 1 from the outer side.





## Change to REAR TANK (2)

Step 1



Step 2



**CAUTION:** Before starting the motorcycle, ensure that the fuel valve position matches the switch's position. **Starting the motorcycle with the valve in a position other than the switch's position can cause serious damage to the motorcycle.**

For rear tank (2), in step 1 the button must be in the inner position, and the fuel switch must show the number 2 from the upper side.





## ADJUSTMENT BEFORE DRIVING

### Adjustment of steering handle

Adjust the steering handle to the most comfortable position according to your height and driving posture. Loosen the four fastening bolts (1) and slightly turn the handle frontwards or backwards to find your comfortable position.

The handlebar mounts have 3 possible positions on the triple clamp, you can choose to place the handlebar forward to adjust the driving position to your needs.

If adjustment is required, please go to the authorized dealer by **RIEJU**.



#### CAUTION:

- After adjusting the steering handle, please repeatedly confirm whether the left and right hands interfere with the fuel tank when turning to the extreme left and right positions. If so, please re-adjust until there is no interference, otherwise your control ability of the vehicle will be affected.

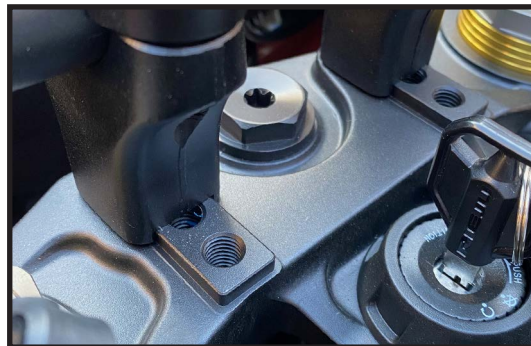
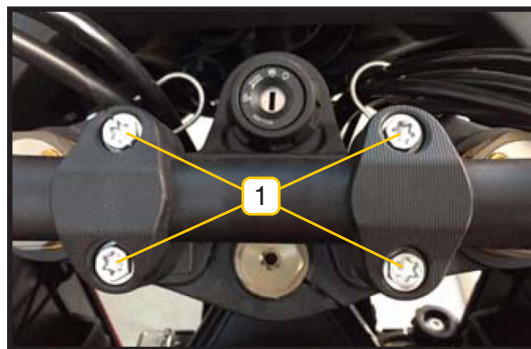



### Mirror adjustment

Adjust the rear-view mirror (1) to the correct position according to your height and driving posture.

Loosen the nut (3) to adjust the mirror rod (2) and determine the rear lock nut (3).

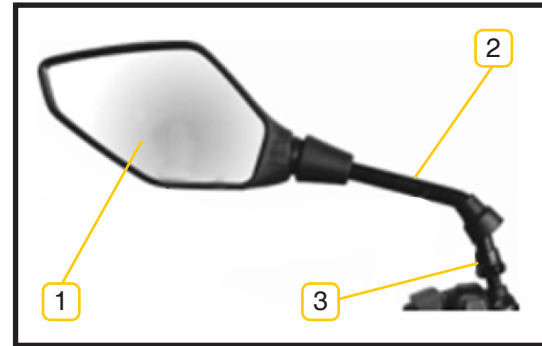

#### CAUTION:

- Adjusting the rearview mirror during the driving process will reduce your control of the vehicle. Do not adjust the rearview mirror during the driving process.



## Adjustment of front brake handle

The distance can be adjusted in 5 gears. The method is as follows:

1. Please push the handle (3) forward during adjustment.
2. Turn the adjustment knob (2) to the position you want.
3. Release the push forward handle (3) and the adjustment is completed.



### CAUTION:

- It is dangerous to adjust the front brake handle when driving the vehicle. Leaving the steering handle will reduce the control ability of the vehicle.





### Adjustment of shift pedal

When the vehicle is running, the road conditions are changeable. The use of shift pedal can change the speed and traction capacity of the vehicle. The shift pedal lever can be adjusted to suit your driving habits.

1. First loosen and lock the two nuts (1) of the transmission connecting rod (2).
2. Then rotate the speed change connecting lever (2) to adjust the of the pedal (3) to the comfortable position.
3. Finally, lock the nut (1).

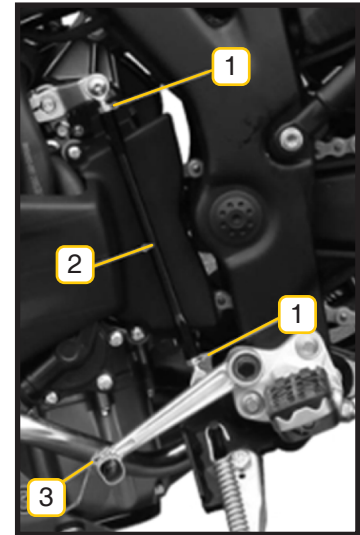



## Adjustment of rear brake pedal

The height of the rear brake pedal (3) shall be kept at an appropriate position. If the position is high, it is easy to step on in use, so that the brake pad and brake disc will often rub together, resulting in long-term heating and damage of the pad and brake disc.

If the free brake pedal travel is not correct, please adjust it according to the following method: the free brake pedal travel is 35mm to 35mm.

1. Loosen the locknut (2).
2. Turn the adjusting nut (1) clockwise or counter-clockwise.
3. Clockwise rotation increases the pedal height, otherwise, it decreases.
4. Lock the lock nut (2) when the height of the brake pedal (3) is adjusted to the appropriate position.

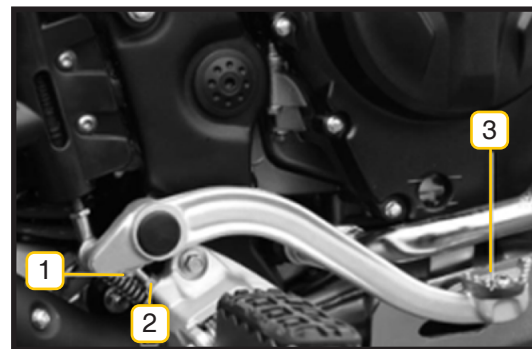

### CAUTION:

- After adjustment, press and release the brake pedal repeatedly and confirm that the pressure point can be clearly felt.
- If you can't feel the pressure point clearly, please consult the authorized dealer of RIEJU for treatment.
- If the adjustment is not correct, there will always be force between the pad and brake disc, which will damage the pad and brake disc.



### Adjustment of throttle control handle

The throttle control handle is used to control the speed of the engine. Turning to its own direction is acceleration, and vice versa.

The adjustment of throttle cable clearance is as follows:

1. Remove the rubber sleeve (1).
2. Loosen the locknut (3).
3. Rotate the adjuster (2) to adjust the clearance of the throttle cable to 2 ~ 4mm.
4. Lock nut (3).
5. Reinstall the rubber sleeve (1).

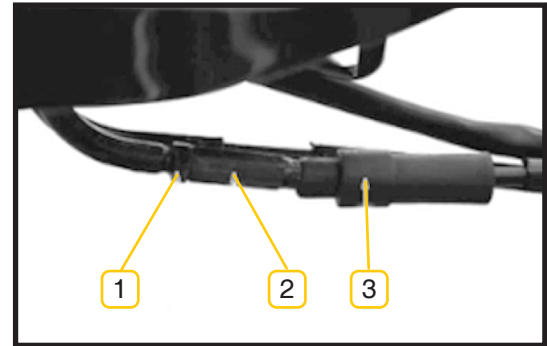

#### CAUTION:

- After the throttle cable clearance adjustment is completed, ensure that the throttle control handle can return automatically, and the idle speed should not increase.
- After the throttle cable clearance is adjusted, turn the steering handle to the left and right limit positions respectively, and the idle speed shall not increase.



## Adjustment of clutch handle

When starting the engine, braking or shifting gear, hold the clutch handle to separate the clutch pad, so as to cut off the transmission power of the engine. The free stroke at the end of the clutch handle is between 5 ~ 8mm. If it is incorrect, please adjust it according to the following methods.

1. Remove the rubber sleeve (1).
2. Loosen the locknut (3).
3. Rotate the regulator (2) to ensure that the free stroke is between 5 ~ 8mm.
4. Lock nut (3).
5. Reinstall the rubber sleeve (1).

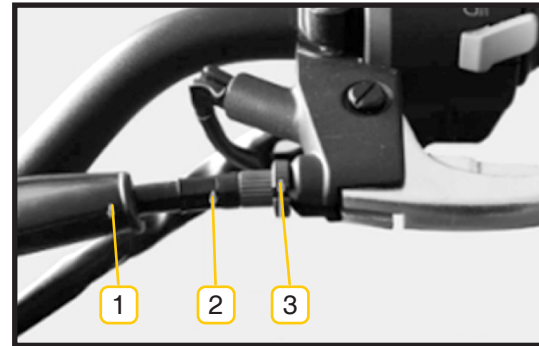

### CAUTION:

- The free stroke of the clutch handle is too large, which is easy to cause wear and failure of the clutch and shift mechanism.



### Adjustment of rear shock absorber

The preload of the rear shock absorber is adjusted to adapt to different drivers and loads. The spring preload of the vehicle is adjustable.

Improper adjustment of the preload of the rear shock absorber will affect the riding comfort.



**CAUTION:** Please do not blindly and arbitrarily adjust the preload of the rear shock absorber. Improper adjustment will weaken your control over the vehicle.

### Spring preload adjustment

The pre pressure adjustment knob of the rear damping spring is located on the left side of the vehicle and below the rear of the fuel tank, as shown in figure 1.

1. Decrease the spring preload counterclockwise.
2. Increase the spring preload clockwise.



Fig. 1



### Compression adjustment

The rear shock absorption compression adjustment knob is located on the right side of the vehicle, on the lower right side of the seat cushion and above the rear shock absorber, as shown in figure 2. From top to bottom, the adjustment method is as follows:

1. Reduce compression damping counterclockwise.
2. Increase compression damping clockwise.



Fig. 2

### Rebound adjustment

The rear shock absorber rebound damping adjustment is located at the bottom left of the rear shock absorber, as shown in figure 3. It needs to be adjusted with a flat screwdriver.

1. Reduce the rebound damping counterclockwise.
2. Increase the rebound damping clockwise.

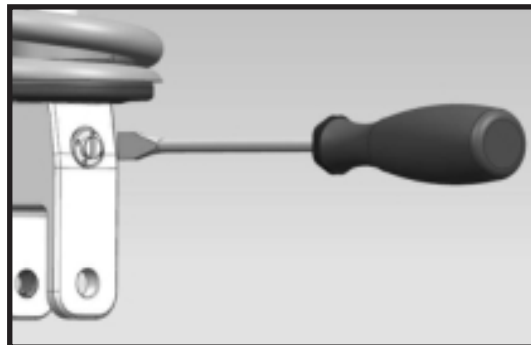

Fig. 3



### Headlamp light height adjustment

The headlamp shall maintain a reasonable height when the shock absorption is adapted to different loads. In order to ensure driving safety at night, the beam inclination of headlamp is adjusted to meet the requirements of different loads on the light height of the whole vehicle. The position of the adjuster is located behind the headlamp, as shown in the figure.

Rotate the light clockwise to turn it down, otherwise the light will turn it up.

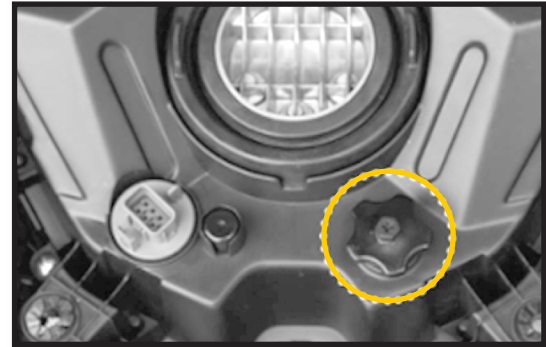



## **RUNNING IN OF NEW VEHICLE**

### **Engine running in**

Whether in hot or cold state, the engine shall have sufficient idle running time before starting to make the oil flow to all lubricating parts.

During running in, the engine speed at 0 ~ 500km shall not exceed 5000r / min, and the engine speed at 500 ~ 1000km shall not exceed 7000r / min.

During the running in period, the gear and speed of the engine should change frequently, and do not run continuously for a long time under a certain gear and speed.

During the running in period, when the engine is running at a fixed low speed (light load), the wear of parts will be intensified and the matching will be poor. Therefore, do not drive at an average speed with light load for a long time.

During running in, avoid sudden acceleration and braking except in case of emergency.

Do not drag the gear to drive, pay attention to downshifting in advance when decelerating, and keep the engine in a comfortable running state all the time.

Long distance riding shall be avoided during running in, so that the engine has enough rest time.





The running in period has a great impact on the service life and fuel consumption of the vehicle, so please read the manual carefully before use (in the initial 500km journey, correct use of the vehicle will enable you to ensure the performance of the vehicle and have fun driving).

### **Tyre running in**

The surface of the new tire is smooth. If you ride at high speed or bend at this time, it is easy to be dangerous. In order to achieve the maximum grip of the tire, the running in process is very necessary.

In the first 200km, you can run in the tire through low-speed curve until all angles of the crown are completely run in.

The bulge on the tire crown has the risk of causing accidents. The way to avoid the bulge on the tire crown is tire running in.

### **Running in of braking system**

In the initial 500 km period, the new brake discs are still in their original state, so their optimal friction level is not reached. As compensation for the loss of braking efficiency, you can control the brake handle with greater force.



#### **CAUTION:**

- When running in a new car, the engine speed should change from time to time. Do not drive continuously at a certain speed. The purpose is to properly stress the components to make them fully fit, but do not apply excessive load.



## VEHICLE DRIVING

### Pre driving inspection

If the vehicle is not inspected before driving, the probability of accident and vehicle damage will be increased. Please pay attention to the following items:

#### Steering system

- The steering handle turns flexibly without jamming.
  
- The steering column is not moving or loose.

#### Throttle

- The throttle cable clearance is correct.
  
- The throttle operates smoothly without jamming.

**Brake**

- The brake handle and brake pedal operate normally.
- The brake fluid is at the correct level of the brake oil cup.
- The medium pressure point is clear during braking.
- The brake disc and pad shall be free of water and oil stain.

**Shock absorber**

- Press to return smoothly.

**Drive chain**

- No excessive wear and damage.
- The chain tension is correct.



## **Tyre**

- The tire pressure is correct.
  
- The tread depth is not excessively worn.
  
- The tread is free of cracks and wounds.

## **Engine oil**

- The oil level is correct.

## **Cooling system**

- The coolant level is correct.
  
- No coolant leakage.

## **Lighting**

- The headlamp / front position lamp, tail lamp / brake lamp, turn signal lamp, headlamp and instrument lamp can be turned on normally.



### **Indicator light**

- ☒ The high beam indicator, neutral indicator and steering indicator controlled by the brake handle switch can indicate and work normally. The oil pressure alarm lamp, EFI fault indicator lamp, water temperature alarm lamp and oil level alarm lamp do not flash or normally light after the engine is started.

### **Horn**

- ☒ The function is normal.

### **Engine shutdown switch**

- ☒ The function is normal.

### **Side support**

- ☒ It can be retracted and played normally.

### **Rearview mirrors**

- ☒ On the whole vehicle, keep the vehicle vertical, and the objects within 10m at the rear end and 4m wide can be clearly seen from the rearview mirrors.
- ☒ If not, please adjust the angle of the rearview mirrors.



## Engine start

Check whether the engine shutdown switch is in “○” position.

Insert the key into the ignition switch and turn it to the “○” position.

Confirm whether the engine is in the neutral position, and the neutral indicator “N” of the instrument will be on.

After the above conditions are met, hold the clutch with your left hand to ensure safety, and press the electric start button “⚡” with your right hand. At this time, it is not necessary to turn the throttle handle. Release the electric start button immediately after the engine is ignited.

Start the engine and allow the engine to idle until it is fully warmed up.



### CAUTION:

- The colder the weather, the longer the engine needs to be preheated. Sufficient preheating can achieve better lubrication and reduce engine wear.
- Please do not let the vehicle idle for a long time. Poor heat dissipation is likely to cause overheating of the engine and damage internal parts.
- In cold environment, to facilitate start-up, the accelerator can be properly rotated while pressing the electric start button.
- The lubrication of the engine only works when the engine is running, so do not let the engine drive the vehicle for a long distance when the engine is stopped.
- After the engine is started, please check whether the indicator light of the instrument is abnormally on or flashing. If so, please shut down the engine immediately and check accordingly.



This series of vehicles are designed with interlocking switches of ignition circuit and starting circuit. The engine can only be started under the following conditions: the gear is in neutral, the ignition switch and flameout switch are in “O” open position, and hold the clutch handle to ensure safety.

**CAUTION:**

- The irritating tail gas emitted by motorcycles contains carbon monoxide, a colorless and odorless highly toxic gas. Do not idle the engine for a long time in poorly ventilated places or rooms without ventilation equipment, so as to avoid the risk of gas poisoning.



## Road driving

1. Get on the bike from the left and sit across the seat cushion.
2. Stow the side support.
3. Adjust the vehicle to be vertical to the ground, straighten the steering handle and keep the wheels forward.
4. Hold the clutch.
5. Slowly turn the throttle control handle in the acceleration direction, and gently release the clutch handle. The clutch engages and the vehicle starts to start.
6. Helmet, gloves, riding boots and other special protective clothing and trousers must be worn before driving. These are also necessary for short distance driving.
7. If you drive too fast, please note that the following factors will adversely affect your handling:
  - Improperly adjusted damping spring preload.





- ☒ Loose clothes.
- ☒ Overweight and unbalanced loads.
- ☒ Even a small amount of alcohol or some drugs that have an effect on nerves will have an adverse impact on your perception and response. Never drive after drinking or taking drugs that have an effect on nerves.

**CAUTION:**

- Whether the engine is in high temperature after operation or before starting in cold state, the engine shall have sufficient idle running time.
- This allows oil to penetrate all important components.

**CAUTION:**

- The vehicle cannot start with the high gear of the transmission, which will cause engine damage. You must start with the first gear.

**CAUTION:**

- Before starting the vehicle, make sure that the side support is retracted to the upper limit position, otherwise the side support may touch the ground and fall when turning left.



## Variable speed device

The transmission enables the engine to run smoothly within the normal speed range.

The gear ratio is carefully designed to adapt to the characteristics of the engine. The driver should select the most suitable gear according to the driving conditions, and never use low gear and high speed.

In order to ensure smooth gear shifting and reduce the impact of rear wheels, with the use of clutch, reduce the vehicle speed or engine speed before changing to low gear; Increase vehicle speed or engine speed before changing high gear.

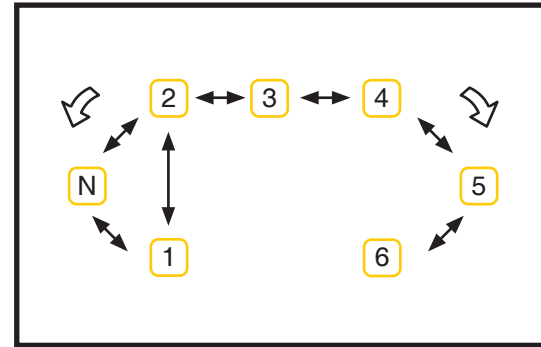

### CAUTION:

- At any time, do not use the semi clutch method to control the speed. It is forbidden to hold the clutch and slide in any gear.



## **Braking and parking**

When braking use front and rear at the same time to reduce speed.

When the vehicle speed is low enough, shift into low gear and hold the clutch tightly. Put the gear in neutral, brake and stop completely.

During front braking, because the body leans forward and the front shock absorber is pressed down, more weight of the whole vehicle will be instantly transferred to the front wheel, so the braking of the front wheel will be more reliable. Therefore, when braking is used, the braking force of the front braking is greater than that of the rear braking, making it easier for the vehicle to stop.

When you are driving on a mountain road, it is a potential danger to only use the rear brake. In extreme cases, the brake will overheat and cause serious damage.

Make rational use of the front and rear brakes and the deceleration function of the engine.



## Fuel

The fuel consumption parameters you see when you buy a vehicle are the data that the vehicle drives at a constant speed at a certain speed with the least fuel consumption, which is very different from your usual operation, so you will find that the actual fuel consumption is higher than the fuel consumption parameters during actual driving.

- ☒ Driving in urban areas is unfavorable to fuel consumption. Frequent stop and go means that the engine starts frequently.
- ☒ The vehicles often drive at the economic speed. The economic speed of this series of vehicles is 90km / h, the speed is increased from 100km to 140km / h, and the fuel volume is increased by about 20%.
- ☒ Avoid short distance rides. The fuel consumed by starting the vehicle in the first kilometer is more than twice that under normal conditions, because the engine has not reached the optimal operating temperature.
- ☒ Insufficient tire pressure will increase the rolling resistance of the wheels, thus increasing fuel consumption.
- ☒ Checking and maintaining your vehicle in strict accordance with the maintenance cycle is also an important part of saving fuel.



## Fuel evaporation

When the fuel evaporation system fails, please contact **RIEJU** service shop for maintenance. Do not change the fuel evaporation system, otherwise it may not meet the requirements of fuel evaporation emission regulations.

After disassembly and maintenance, check whether all pipelines are well connected and whether the pipeline joints are free of air leakage, blockage, etc; The rubber hose shall be free from extrusion, fracture, damage, etc.

The fuel vapor in the fuel tank is released into the carbon canister through the desorption pipe. When the engine stops working, the fuel vapor is adsorbed by the activated carbon in the carbon canister; When the engine is working, the fuel vapor in the carbon canister is released to the engine combustion chamber through the desorption pipe to participate in combustion, so as to prevent the fuel vapor from being directly discharged into the atmosphere and causing environmental pollution.

At the same time, the adsorption pipe also balances the air pressure in the fuel tank. When the air pressure in the fuel tank is lower than the external atmospheric pressure, the air pressure in the fuel tank can be supplemented through the carbon canister air pipe and adsorption pipe; Therefore, ensure that all pipelines are unobstructed, prevent blockage, extrusion and other phenomena, and ensure that the anti tilt valve is installed correctly, otherwise it may cause damage to the fuel pump or fuel tank, deformation, rupture or other parts.

The fuel evaporation control system works according to the following principles:



- ☒ After the gasoline in the fuel tank is heated, the gasoline evaporates, passes through the dump valve to the tank end of the carbon tank and is adsorbed by it.
  
- ☒ The fresh air is brought into the engine through the throttle pipe to the engine inlet through the purge.



## Catalyst

The emission system of the vehicle is equipped with catalyst, which reduce the harmful components of the engine exhaust. Poor operation of the engine will damage the catalyst, so follow the following behavior:

- ☒ Regular maintenance must be carried out according to the provisions in the manual.
- ☒ In case of unstable engine operation, please go to the authorized RIEJU dealer for troubleshooting as soon as possible.
- ☒ When the fuel alarm light is on, replenish fuel as soon as possible. Too low oil level will cause irregular fuel supply.
- ☒ Do not start the engine in the form of a cart or trailer.
- ☒ The ignition can only be switched off at idle speed.



### CAUTION:

- The catalyst is a very delicate component.

Unleaded petrol E5 or E10 should be used. The use of other fuels (petrol or diesel) will damage the catalyst and other vital engine components, even if in a very small quantity.



### **CAUTION:**

- Do not park or drive on inflammables, such as hay, etc. the temperature of the catalyst is very high, which will ignite these objects.

## **Troubleshooting**

The troubleshooting content can help you find the cause of the general problem. Of course, this is only some basic judgment. If it still cannot be eliminated, please send the vehicle to the dealer authorized by **RIEJU** for treatment.

### **The engine will not start**

- Neutral, the flameout switch is in the open position.
- In gear, the flameout switch is in the open position, the clutch is clenched, and the side support is retracted.
- Whether the fuel is sufficient.
- Whether the battery power is sufficient.





### Difficult engine start

- ☒ Whether it is in a low temperature environment. If so, please bring a little throttle when starting.
- ☒ Battery power loss.
- ☒ If the oil is too sticky, judge whether the oil needs to be changed.

### Engine weakness

- ☒ Check whether the filter element of air filter is clean.
- ☒ Check whether the fuel filter is blocked.
- ☒ Whether it is at high altitude.
- ☒ Incorrect maintenance and adjustment will damage your vehicle without finding the cause of the fault. Such damage cannot enjoy the three guarantees policy of **RIEJU**.
- ☒ If you are not sure of any correct operation, please contact the authorized dealer of **RIEJU**.



## INSPECTION AND MAINTENANCE

### Daily inspection

After use under harsh conditions, after rain and after car washing, corresponding lubrication shall be carried out. In order to drive safely, maintaining good lubrication of working parts is a necessary operation to delay service life.

Daily inspection and lubrication points are as follows:

- Clutch handle lever.
- Brake handle lever.
- Brake pedal bearing.
- Side support shaft and side support spring hook.
- Main and auxiliary footrest shafts and return springs.
- Drive chain.

**CAUTION:**

- Except that the transmission chain needs to be lubricated with chain oil, it is recommended to lubricate other lubrication points with color lithium grease.

**Battery maintenance**

The battery is located under the seat cushion. The battery equipped on this bike is a maintenance free battery. It is not necessary to regularly check the position and proportion of electrolyte during the service cycle, but the charging condition should be checked regularly.

**CAUTION:**

- If conditions permit, the battery shall be charged for 30 minutes before the first use, which can effectively prolong the service life of the battery.



## **Battery charging**

If the turbulent voltage of the battery is lower than 12.6V, it is recommended to charge the battery.

Use DC regulated power supply for charging.

The charging voltage is DC ( $14.5 \pm 0.3$ ) V, and the charging current does not exceed 1.2A; The charging time is 6 ~ 8 hours. Please do not exceed the maximum charging current.

Overcharging of the battery will shorten the service life of the battery. Please do not overcharge the battery.

Be sure to disconnect from the on-board circuit before charging the battery.

Regularly check whether the electrode and cable head of the battery are clean. If they have been corroded and oxidized, they shall be cleaned in time.

When the vehicle is not used for a long time, disconnect the negative pole of the battery. If the vehicle is not used for more than one month, the battery shall be charged once a month. If the battery is not charged for a long time, it is easy to fail naturally.

A suitable charger shall be used to charge the storage battery and strictly follow the instructions of the charger.



Disconnect the battery from the charger immediately after it is fully charged. The battery takes a long time to fill. Please properly dispose of the waste battery or waste electrolyte, so as not to pollute the environment.

**CAUTION:**

- The battery will produce combustible hydrogen. Please keep the battery away from heat sources and sparks.
- Wiping the battery with a dry cloth will cause static sparks, so please wipe it with a wet cloth to avoid static electricity.



## Disassembly and assembly of battery

Turn off the ignition key before removing the battery.

When removing the battery, remove the negative terminal first and then the positive terminal.

When installing the battery, install the positive terminal first and then the negative terminal.

After each new installation of the battery, turn on the point switch and wait for 1 minute before starting the engine to initialize the electronic equipment.

When the vehicle is not used for a long time, the battery is not disconnected, and the electrical circuit is electronic products (such as clock) will gradually run out of power, which may lead to insufficient power when the battery needs to be used.

If the vehicle is not used for more than one month, disconnect the connecting wire of the battery or charge the battery before use.

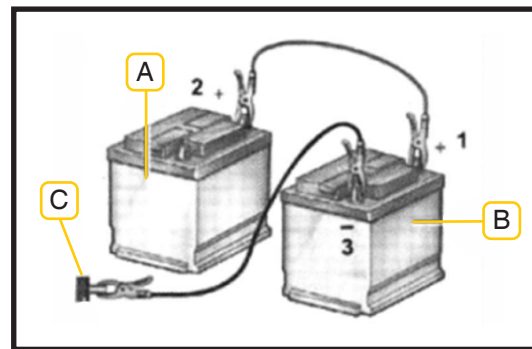

### CAUTION:

- Do not turn the battery upside down, which will cause the internal electrolyte to seep out of the vent hole.



### **Use of external power supply**

When the battery power cannot meet the engine starting, it can be started with the help of external power supply.

When starting with external power supply, special spring clamp with complete insulation at both ends shall be used to prevent short circuit and fire jumping caused by wire contact.

Battery a is the on-board power supply, and battery B is the external power supply.

The positive pole 1 of the external power supply B is connected to the positive pole 2 of the on-board power supply a, and the negative pole of the external power supply is grounded on the metal body of the vehicle. Start the engine. If the start fails, wait a few minutes before starting the next time to protect the engine and battery.

Before removing the starting wire of the external power supply, let the engine run for a few minutes, then disconnect the negative wire and ground wire, and then disconnect the positive wire.



## Maintenance of air filter

Check the air filter and replace according to the maintenance Schedule or replace it sooner if it is damaged or there is dust, mud or pollution on it.



### **CAUTION:**

DO NOT clean it with air pressure, water or detergents.







## Engine oil maintenance

Engine oil ensure the effective lubrication of parts in the engine. In addition, it can also help the engine cool down and play a cooling role. In

addition, engine oil can also help the engine seal, so the maintenance of engine oil is very important.

### Inspection of oil level:

The oil level inspection and oil injection are on the right side of the engine cover.

### Method for checking oil level:

- ☒ The engine is cold.
- ☒ Then make sure the body is vertical.
- ☒ Check the oil level from the oil sight glass.
- ☒ The correct oil level height of the oil should be between the upper scale 2 and the lower scale 3 of the oil observation window 1.

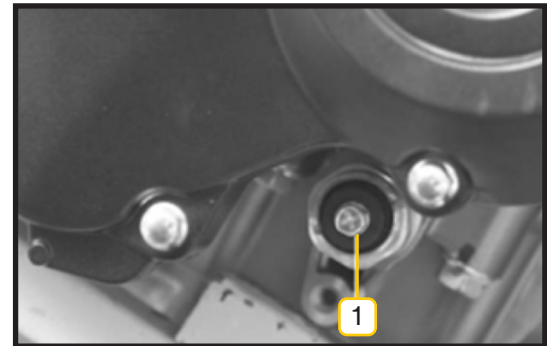
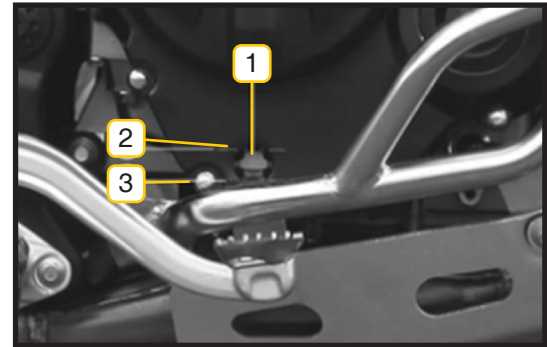



If the oil level is higher than the upper scale mark 2, some oil needs to be drained.

If the oil level is below the lower scale mark 3, a certain amount of oil needs to be injected.

Whether the oil is drained or injected, the oil level shall be rechecked according to the above oil level inspection method after the operation is completed.

#### **Method of draining oil:**

If the oil level is too high, use a socket wrench to remove the oil drain bolt (1) located under the left side of the engine.

After draining an appropriate amount of engine oil, reset and lock the oil screw 1.

The engine will be damaged if the oil level is too low. Similarly, the engine will be damaged if the oil level is too high.

Make sure that the oil level is at the correct position.

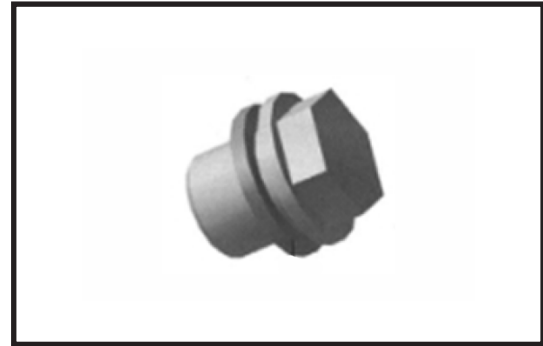

**Change engine oil:**

Change the engine oil when each maintenance cycle is reached.

The oil change should be carried out when the engine is hot, so that the old oil can be drained more thoroughly.

**Replacement method:**

Use the auxiliary parking rack to keep the vehicle upright. Unscrew the oil filler cap counterclockwise.

Place the oil collecting pan under the oil drain bolt, remove the oil drain bolt with a tool and drain the old engine oil.

Lock the oil drain bolt before adding new oil.

**CAUTION:**

- When reinstalling the oil drain bolt, replace the oil drain bolt and sealing washer. If the removed sealing washer is still used, it is easy to cause oil leakage at this position.

**CAUTION:**

- Although it will be more thorough to drain the old engine oil when the engine is hot, the engine oil and muffler will be hot and burn people, please wait until the drain bolt and muffler are basically cooled before draining the old engine oil.



## Replace the oil filter element

When each maintenance cycle is reached, replace the engine oil filter element.

The oil filter element should be replaced when the engine oil is drained.

- ☒ Remove the lower shroud.
- ☒ Place a piece of oil absorbing paper or cotton cloth under the engine oil filter cover to prevent oil overflow from polluting the engine surface when the engine oil filter cover is removed.
- ☒ Remove the oil filter element at the front of the engine with the special tool.
- ☒ Take out the oil filter element and drain all the oil.

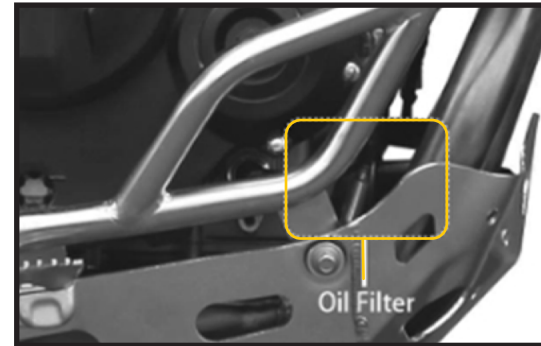



- ☒ Replace the oil filter element with a new one.
  
- ☒ Replace the oil filter element. It is very important to correctly position the O-ring on the oil filter element cover during installation, otherwise there will be leakage at this position.

**CAUTION:**

- Check the integrity of the O-ring of the oil filter element cover, and replace it if necessary. Replacing the wrong oil filter element will damage the engine. The pure parts provided by **RIEJU** must be used.



### Fill in engine oil

Confirm that the oil filter element has been replaced and the oil filter element cover has been assembled.

- ☒ First inject about 2.7L of new “GRO SMART 10W40 motorcycle engine oil” from the oil filler of the engine, then tighten the oil filler cover of the frame, run the engine at different speeds for 5 minutes, and check whether the disassembled parts have leakage during operation.
  
- ☒ Finally, check the height of the oil level.



#### CAUTION:

- Oil grade: GRO SMART 10W40; Oil filling capacity: 2.7L.
- Please dispose of the replaced old engine oil and engine oil filter element in an environmentally friendly manner.



#### CAUTION:

- Unqualified or inferior engine oil will damage the engine, damage parts of the EFI system, and shorten the service life of the catalyst in the spark plug and muffler, so please do not use it.



## Coolant maintenance and inspection

The coolant can take away and dissipate the heat of high-temperature parts of the engine, so as to keep the engine at normal working temperature.

Check the coolant level and replenish coolant at the expansion tank.

Engine off.

Since the coolant will expand due to heating, check that the coolant level should be in the cold state.

Keep the body vertical.

Observe the liquid level at the expansion water tank, and the liquid level shall be between lower (3) and upper (2).

If the coolant is below the lower line, add it from the expansion tank port (1).

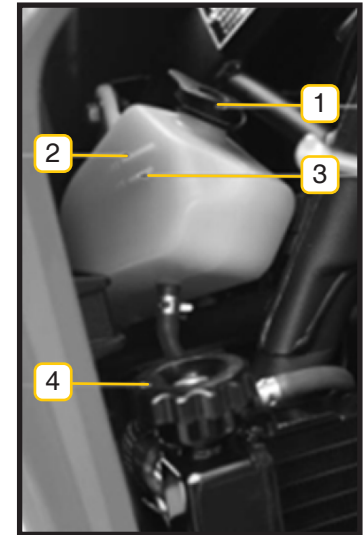



If the cooling liquid level is too high, the coolant will expand due to the temperature rise in use, so too high cooling liquid level will cause the coolant to eject from the overflow pipe. To avoid scalding, do not overfill the coolant.

If you replenish coolant frequently, it indicates that there is a fault in the cooling system. At this time, please go to the dealer authorized by **RIEJU** for treatment.

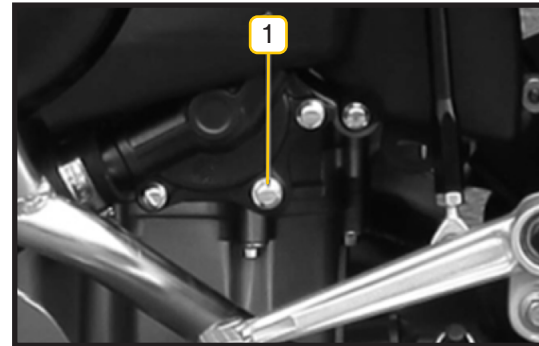

**CAUTION:**

- If it is found that the expansion tank has been completely dried out during use, please do not supplement the coolant without authorization, because it is necessary to eliminate the gas that may have entered the cooling system. At this time, please go to the authorized dealer of **RIEJU** for treatment.





## Coolant replacement

### Coolant discharge:

Use a special parking rack to keep the vehicle upright. Place a drip pan under the engine.

Remove the drain bolt (1). Because the whole heat dissipation system is connected, all coolant will be discharged from the drain.

After the old coolant is completely drained, install the drain bolt (1) back.

### Coolant filling:

The coolant needs to be added from the radiator and expansion tank.

Open the radiator water tank cover and observe whether the coolant is full. While filling, pinch the water inlet and outlet pipe to exhaust until it is full, and then cover the radiator water tank cover.

After covering the radiator tank cap, start the engine and run for half a minute so that the coolant can fill all places that need cooling.

Turn off the engine and load the radiator tank again after the engine is cooled. Check whether the coolant at this position is full. If it drops, return to the full state. Cover the radiator tank cover and repeat the process until it is full. If necessary, repeat several times.



Finally, remove the black rubber cover of the expansion tank and add coolant to the specified position between lower and upper.

When the air temperature is lower than that indicated on the coolant label, the coolant with higher anti-freeze performance shall be selected.

The tested coolant of **RIEJU** is ethylene glycol coolant with freezing point of - 45 °C. Visit the **RIEJU** authorized dealership for a replacement.



**CAUTION:**

- Do not fill the coolant system with tap water, otherwise the cooling system will be damaged.
- Due to different formulations, different types of coolants cannot be mixed with each other.



**CAUTION:**

- In the process of filling coolant, when you open the radiator tank again after the engine, be sure to let the engine cool, otherwise the high-temperature liquid in the radiator will spray out as you open the radiator cap, resulting in scalding accidents.



## Brake fluid maintenance

Braking is an important medium for transmitting power in the hydraulic braking system. It needs reliable high and low temperature performance and good low temperature fluidity, as well as anti-corrosion protection performance. Please be sure to select the correct brake fluid.

The front wheel brake fluid cup is shown in figure, and the rear wheel brake fluid cup is shown in figure.





## Inspection of brake fluid

If the brake fluid level in the brake oil cup is too low, air will enter the brake system, which will significantly reduce the braking efficiency. It is necessary to check the brake fluid level regularly.

Check the brake fluid level and replenish the brake fluid at the front and rear brake fluid cups.

The liquid level shall not exceed the maximum (max) mark. When the liquid level is lower than the minimum limit (min), please add it in time.

The brake note is corrosive to a certain extent. Splashing on the paint surface or plastic surface will corrode the surface of the object.





### Model of brake fluid

When the brake fluid absorbs water or impurities, it shall be replaced or filtered in time, otherwise it will cause insufficient braking pressure and affect the braking effect. This is more important in humid areas.

If the brake fluid has been used continuously for more than 2 years, it is easy to deteriorate due to long service time. It should be replaced in time.

The model of brake fluid is dot5. Please dispose of the replaced old brake fluid in an environmentally friendly manner.



#### CAUTION:

When it is necessary to replenish the brake fluid, opening the brake oil cup cover without authorization may cause the entry of gas and moisture, which will greatly reduce or invalidate the braking performance. At this time, please go to the authorized dealer of **RIEJU** for replenishment or replacement.



#### CAUTION:

Do not mix brake fluids of different types and brands.  
Due to different formulations, the performance index of mixed brake fluid will be reduced.



## Drive chain maintenance

The transmission chain of this series of vehicles is an oil sealed chain. There is a special O-ring at the chain pin. The sealing ring is sealed with grease. The chain is of the type of non open pot ring, so special tools are required to replace the chain. If necessary, please contact the authorized dealer of **RIEJU**.

Check or adjust the transmission chain before driving every day. Please confirm whether there are the following problems:

- Loose chain pin
- Chain plate rusted
- Inflexible chain link rotation

If any of the above problems are found in the chain, please contact the authorized dealer of **RIEJU** for treatment. The wear of the transmission chain will also cause the wear of the sprocket. Please confirm whether there are the following problems:

- The sprocket is excessively worn
- The teeth are broken or damaged



- ☒ If any of the above problems are found on the sprocket, please contact the authorized **RIEJU** dealer for treatment.

Dirt and dust on the chain will affect the service life of the chain. Please clean and lubricate it regularly. Because there are O-rings and grease at the chain pin, incorrect cleaning and lubrication will damage the O-rings and grease, which will accelerate the reduction of the service life of the chain.

Do not use a wire brush to clean the chain.

After cleaning, wipe off water or neutral detergent immediately and dry the chain for lubrication.

Use the special chain oil for oil seal chain to evenly coat the inner and outer chain plates of the chain. After completion, wipe off the excess chain oil.

Some chain lubricants contain solvents and additives that can damage the sealing ring. Please use special oil seal chain lubricant.



**CAUTION:**

- Please clean the chain with water or neutral detergent.
- Do not use volatile solvents to clean the chain, such as paint thinner, gasoline, etc.
- Do not use a high-pressure cleaner to clean the chain.



## Adjustment of drive chain

Too loose or too tight drive chain is incorrect.

If the chain looses too much, it is easy to cause the chain to separate from the sprocket and cause accidents.

Too tight chain will not only affect the service life of the chain, but also increase the transmission resistance.

The correct chain looseness is shown in the figure. If the looseness of your vehicle's transmission chain cannot meet the above requirements, it needs to be adjusted as follows:

Use a special parking rack to keep the vehicle upright.

Loosen the rear axle nut (3) and adjusting nut (1), and adjust the bolt (2) according to the looseness

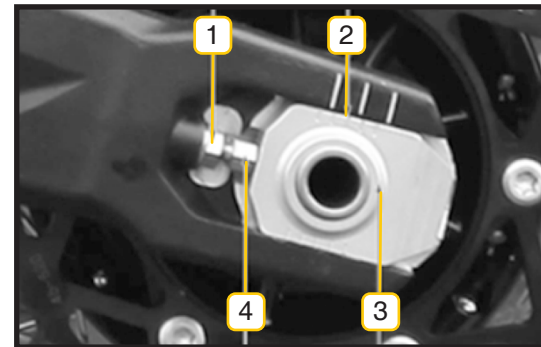
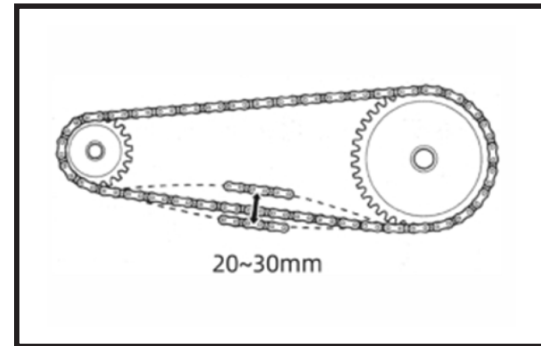





of the chain.

If the chain looseness is too large, rotate the bolt counterclockwise; Conversely, if the chain looseness is too small, rotate the bolt clockwise to make the adjustment top block consistent with the scale (2) on the flat fork.

Lock the rear axle nut (3) and the left and right adjusting nuts (1)

Specification and model of transmission chain: 520 chain disk, 114 rivets.

Locking torque of adjusting nut: 14 Nm. Locking torque of rear axle nut: 95 Nm.

### **Tire maintenance**

Abnormal tire pressure will reduce the service life of tires.

Low tire pressure will make it difficult to turn and aggravate tire wear.

Too high tire pressure will reduce the contact area between the tire and the ground, and the vehicle is easy to slip and lose control.



At high speed, the valve core of the tire tends to open due to the action of centrifugal force. In order to prevent sudden air leakage, a metal lined rubber cover is equipped and installed on the valve core by threaded connection.

Tire inflation pressure is directly proportional to tire temperature. Therefore, the tire inflation pressure can be corrected in the cold state only when the tire temperature is basically consistent with the ambient temperature.

Under normal temperature, please check the tire pressure according to the following table data:

	Ride alone	Double riding
Front wheel	220Kpa	250Kpa
Rear wheel	220Kpa	250Kpa



**CAUTION:**

- Abnormal tire pressure will affect the handling performance of the vehicle and may lead to an accident.
- Overloading can lead to tire failure and loss of control of the vehicle.
- Check the tire pressure at least once a month.



### Inspection of tire wear limit

The tires have wear marks on the main tread.

When the tire is worn to the mark, it can no longer be used.

There is a wear mark near the twi mark on the edge of the tire. The wear mark is located in the drainage groove of the tire crown and is in a convex hull state. When the convex hull is worn, it indicates that the wear exceeds the mark. Please replace the tire as soon as possible.



#### CAUTION:

- Excessively worn tires can puncture the tires and cause the vehicle to lose control.
- When the tire pattern of the vehicle is worn to the minimum allowable depth, its operability and grip will be greatly weakened.



## **Tire repair**

To repair the small hole on the tyre without inner tube, remove the tire and patch it inside the tire. Do not use external repair methods, because the centrifugal force of the tire will loosen the repaired place when driving at high speed.

The vehicle speed shall not exceed 80 km / h within 24 hours after repairing the wheel.

If the side of the tire is damaged, or the damaged part of the tire is greater than 6mm, the tire cannot be repaired.

Check the tire. If there are many obvious damages on the tire, such as damage, scratch or wear to the limit, the tire must be replaced.



## Tire replacement

When changing tires, do not use tires with different brands, models, patterns and different degrees of newness on the same vehicle.

The vehicle after tire replacement needs dynamic balance inspection and correction. If the dynamic balance is poor, the operability of the vehicle will be reduced and the tire wear will be uneven.

The side of the tire marked with the rolling direction is marked with an arrow. The tire must be used according to the specified rotation direction, so as to prevent water skiing, improve adhesion, reduce driving noise and prolong wear life.

The tires of the specified model have been strictly tested and verified, and can meet the use requirements of most roads. Other untested tires cannot guarantee their adaptability or safety.

Tubeless tire is sealed at the contact part between rim and tire lip.

In order to avoid air leakage, disassembly and installation of tubeless tires require special tools and special tire disassembly and assembly machines.

Please let the dealer authorized by **RIEJU** handle the tire replacement. They have the necessary tools and experience.



## Fuse box

Before replacing the fuse, you must understand the cause of the fault and eliminate the fault.

The fuses of this series of models is located under the seat cushion.

The specifications and uses of all fuses are marked.

Vehicle system power fuse 30A: control the power supply of EFI system, ABS system, other electrical loads (instruments, tools, etc.) of the vehicle and the charging circuit of battery. One spare fuse 30A (green).

ABS system motor power fuse 30A: controls the power supply of ABS anti lock system motor. Spare fuse: one 30A.

Signal system power fuse 10A: power supply for control instruments, lamps, horns, flashers, side support flameout switches, relays, etc. Spare fuse: one 10A.

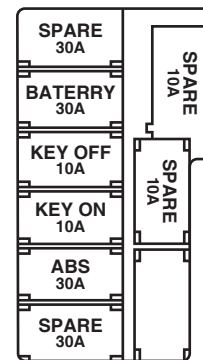



EFI system power fuse 30A: controls the power supply of EFI system ECU, oxidation sensor, ECU diagnostic interface, carbon canister solenoid valve, fuel injector, ignition coil and other EFI systems. Spare fuse: two 30A.

Fan power fuse 10A: controls the power supply of the cooling fan. Spare fuse: one 10A.

Fuel pump power fuse 10A: controls the power supply of the fuel pump. Spare fuse: one 10A.

After checking or replacing the fuse, the cover of the fuse box must be covered, otherwise it is easy to cause serious electrical failure in rainy days or washing the vehicle.

**CAUTION:**

- If the fuse often blows in a short time, it indicates that the electrical system is faulty. Please contact the authorized dealer of **RIEJU** immediately.

**CAUTION:**

- Please select the specified fuses, and do not use substitutes, such as aluminum foil or iron wire.
- Please do not use other safety sheets or direct lap joints other than the specified specifications, otherwise it will have a serious impact on the electrical system, and even cause fire or burn down the vehicle.



## Brake pad

The wear of brake brake pad exceeding the allowable minimum thickness will lead to the decline of braking efficiency and, in some cases, the damage of the system. For the reliability of the braking system, the wear of the brake pad shall not exceed the allowable minimum thickness.

## Replacement of brake pad

The correct way to replace the brake pad requires removing the front and rear wheels, so this task should be carried out by an authorized **RIEJU** dealership.

Both front and rear brake friction plates shall be replaced in a whole pair. If only one of the pair is replaced, it will lead to braking imbalance and accidents.

After the pad is removed, be careful not to operate the brake handle or brake pedal, otherwise it will be difficult to reset the brake piston and there is a risk of fluid leakage.

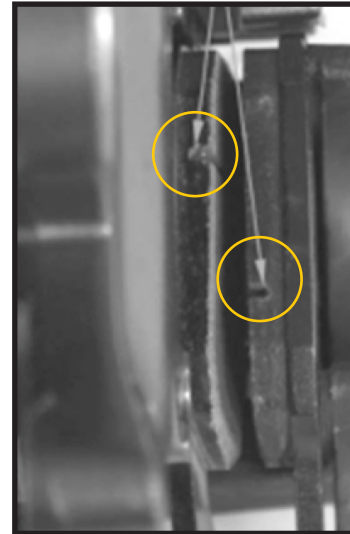





During the process of replacing the pad, do not allow oil or other dirt to adhere to the pad and disc brake disc. If there is any, please clean it up, otherwise the braking slip efficiency will be reduced.

**CAUTION:**

- The front brake of this series of models is a double disc brake system.
- When replacing the pad, it is necessary to replace both sides at the same time to ensure the braking effect and driving safety.

**CAUTION:**

- After replacing the new pad, please repeatedly confirm the brake handle and brake pedal, and confirm whether the pad effectively compresses the brake disc. At the same time, confirm whether the free stroke of the brake handle and brake pedal is correct.



## Oil filter replacement

To change the oil filter, please visit your trusted official **RIEJU** dealership.



### CAUTION:

- The replacement frequency of the oil filter is once every 8.000km
- Please dispose of the replaced old oil filter in an environmentally friendly manner.



## Remplacement of light signal

Losing the signal will put you in danger because the signal light can help others find you and your vehicle more easily. Replace the broken signal lamp in time.

Headlamp, position lamp, turn signal lamp, rear position lamp / brake lamp and license plate lamp are led encapsulated lamps. If they are damaged, they need to be replaced by the authorized RIEJU dealer.



## STORAGE AND CLEANING OF VEHICLES

### Vehicle storage

If your vehicle is not used for a period of time and needs special maintenance, it requires some special materials, equipment and technology. For this reason, it is recommended that you complete these works at an authorized **RIEJU** dealer.

If you want to complete these tasks by yourself, please follow the following methods:

- Completely replace with new oil.
- Block the inlet of the air filter and the exhaust port of the muffler with a rag stained with new engine oil to prevent moist air from entering the engine.
- Completely drain the fuel in the fuel tank.
- Remove the battery, clean the battery surface with neutral soapy water, and clean the oxide on the positive and negative electrodes at the same time.
- Store the battery in a room above 0 °C.



- ☒ Adjust the tire pressure to the specified pressure.
- ☒ Wash the vehicle thoroughly.
- ☒ Spray rubber protective agent on the surface of rubber parts.
- ☒ The appearance of the whole vehicle shall be coated with automobile protective wax.
- ☒ Finally, cover the vehicle with cloth and park it in a dry and ventilated place.

**CAUTION:**

- Charge the removed battery once a month.



## How to reactivate the vehicle

- ☒ Clean the vehicle thoroughly.
- ☒ Take out the rags at the air inlet of the air filter and the exhaust port of the muffler.
- ☒ Completely replace the engine oil and oil filter element.
- ☒ Install the battery.
- ☒ Start the vehicle.



## **Vehicle protection**

According to the use, wash the vehicle frequently and try to keep the vehicle clean and dry.

Clean the dirt attached to the vehicle surface as soon as possible, such as bird droppings, asphalt, salt, etc.

Try to use the vehicle cover. Being exposed to the middle-aged sun for a long time will lead to aging and discoloration of appearance parts.

## **Vehicle cleaning**

Wash the vehicle with cold water.

Wash the vehicle thoroughly with a soft cloth and neutral detergent.

Do not spray the vehicle.

Do not wash the vehicle with high-pressure water.



In rainy days or after washing the bike, there may be a small amount of water mist in the headlamp or steering lamp. It only needs to light the lamp for a period of time, and the water mist will disappear, because the lamps are designed with vent holes, which is normal.



**CAUTION:**

The brake capacity of wet brake will decrease. Please test the brake system at low speed repeatedly after washing the car to make it dry quickly.



**CAUTION:**

The ABS module is located under fuel tank. When cleaning the vehicle, please do not directly flush the ABS module with water to avoid module damage.



**CAUTION:** Do not apply de-greaser to the wheel axles or the chain.



**CAUTION:** Rieju shall not be held liable for using corrosive de-greaser elements that stain or deteriorate motorcycle elements. Rieju shall not be held liable for possible damages and defects caused by using pressurised water to clean the motorcycle.

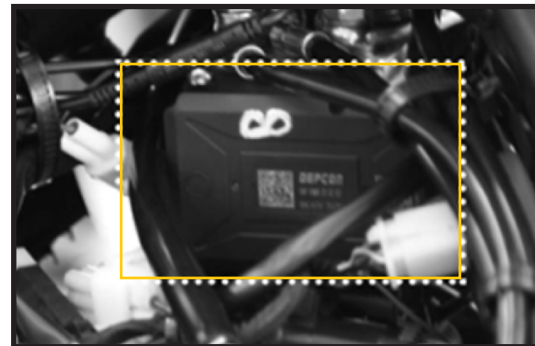





## MODIFICATIONS AND ACCESSORIES

Use only genuine **RIEJU** parts and accessories.

You can obtain genuine **RIEJU** parts, accessories, and other products through authorized dealerships. At the same time, professionals will introduce you to their installation and use.

The safety, practical performance and matching of these parts and products have passed the test, and will be responsible for these products. On the contrary, it will not be responsible for the unauthorized parts and accessories.

Whenever you plan to replace parts, you should comply with all laws and regulations to ensure that your vehicle will not destroy the national requirements for road vehicles and other laws, regulations and specifications.



### CAUTION:

- Unauthorized modification of performance components such as electronic control system will lead to vehicle damage and accidents.



## Maximum Authorized Weight for Suitcases Model Aventura 500



### CAUTION:

We inform all users that the maximum authorized weight for the suitcases of model Aventura 500 is **5 kg**. Any weight above may cause the bracket to break, and such breakage will not be considered as warranty.





## MAINTENANCE TABLE

COMPONENT	500 Km	8.500 Km	16.500 Km	24.500 Km	32.500 Km
Air filter	L/E	C	L/E	C	L/E - C
Engine oil	C	C	C	C	C
Oil filter	C	C	C	C	C
Check oil pump operation	I	I	I	I	I
Check transmission leaks	I	I	I	I	I
Check sump leaks	I	I	I	I	I
Cylinder head, cylinder, and piston				I	
Timing chain / Running time				I	
Valve adjustment				I	I (+24.000 Km)
Segment wear check			I	I	
Clutch			I	I	
Spark plug	I	I	I	C	I - C (+10.000 Km)
Transmission chain tension and wear	I/E	I/E	I/E	C	I/E - C (+10.000 Km)
Battery	I	I	I	C	I - C (+10.000 Km)
Electrical system	I	I	I	I	I
Inspect and adjust carburettor	I		I		I (+6.000 Km)
Fuel line	I	I	I	I	I



Exhaust system	I	I	I	I	I
Controls, accelerator, and cable operation	I	I	I	I	I
Steering and handlebar	I	I	I	I	I
Shock absorbers	I		I		I
Front/rear suspension	I		I		I
Central kickstand/stand	I		I/E		I/E
Brake mechanism / Covering	I	I	I	I	I
Coolant and level	I	I	I	C	I - C (+10.000 Km)
Brake fluid	I	I	I	C	I - C (+10.000 Km)
Brake pads	I	C	C	C	C
Brake disc	I	I	C	I	I - C (+7.000 Km)
Check wheel spoke tension and off-centre	I	I	I	I	I
Tyres: pressure and condition	I	I	I	C	I - C (+10.000 Km)
Engine screws and nuts	I	I	I	I	I
Screws/nuts for each component	I	I	I	I	I



The maintenance schedule may change depending on motorcycle use, driving, environmental conditions, etc...

I: check-adjust / C: change  
E: grease / L: clean



## WARRANTY

Standards regulating manufacturer **RIEJU'S** warranty.

The company **RIEJU** hereby guarantees the end consumer, purchaser of a vehicle manufactured by **RIEJU**, that both the materials and the manufacturing are free from defect, pursuant to the highest quality standards. Consequently, **RIEJU** hereby provides the end purchaser (hereinafter, the “purchaser”), pursuant to the conditions set forth below, with a warranty to repair all material or manufacturing defects found on a new motorcycle at no cost, within the established warranty period and with no limitation in terms of the number of kilometres travelled or the number of hours the vehicle has been operated.

### Warranty Period

The warranty period shall be governed by warranty law in the vehicle's country of sale, in force at the time it is sold.



Warranty claims for defects not brought to the attention of a **RIEJU**-authorised dealer before the end of the warranty period shall be excluded.

### Purchaser obligations

**RIEJU** may legitimately reject warranty claims if, and to the extent that:

- a) The purchaser has not brought the vehicle to any of the inspections and/or to undergo maintenance tasks as required in the user manual, or the date set for these inspections or maintenance tasks has passed. Also excluded from the warranty are defects that appear before the date established for an inspection or



maintenance task that never occurred, or that will occur after the established date.

b) Inspections, maintenance work, or repairs have been conducted by third parties not recognised or authorised by **RIEJU**.

c) Any maintenance or repair has been conducted in violation of the technical requirements, specifications, and instructions set forth by the manufacturer.

d) Replacement parts not authorised for use by **RIEJU** have been used in maintenance or repair work on the vehicle, or if, and to the extent that, fuels, lubricants, or other liquids (including, but not limited to, cleaning products) that were not expressly mentioned in the User Manual's instructions have been used on or in the vehicle.

e) The vehicle has been, in any way, altered or modified or fitted with components other than the components expressly authorised by **RIEJU** as components allowed for the vehicle.

f) The vehicle has been stored or transported in a way that is contrary to technical requirements.

g) The vehicle has been used for a special use other than ordinary use, such as competition, racing, or in an attempt to beat a record.

h) The vehicle has suffered a fall or accident that directly or indirectly causes damages.

## Warranty exclusions

The following articles are excluded from the warranty:

a) Replacements for wear, including, but not limited to, spark plugs, batteries, fuel filters, oil filter elements, chains (secondary), engine output pinions, rear rings, air filters, brake discs, brake pads, clutch disks, bulbs, fuses, carbon brushes, footrest rubber, tyres, chambers, wires, and other rubber components, ex-



haust pipe, and washers.

- b) Lubricants (for example, oil, grease, etc.) and operational fluids (for example, battery fluid, coolant, etc.).
- c) Inspection, adjustment, and other maintenance work, as well as all kinds of cleaning work.
- d) Damage to the paint and consequent rust due to external influences, such as rocks, salt, industrial fumes, and other environmental impacts, or inadequate cleaning with inadequate products.
- e) Damages caused by defects, as well as expenses caused directly or indirectly by the defects (for example, communications expenses, lodging expenses, car hire expenses, public transport expenses, recovery vehicle expenses, emergency messenger expenses, etc.) as well as other financial harm (for example, caused by loss of use of a vehicle, lost income, lost time, etc.).
- f) Acoustic or aesthetic circumstances that do not significantly affect conditions for use of the motorcycle (for example, small or hidden imperfections, normal noise or vibration in use, etc.).
- g) Circumstances due to vehicle ageing (for example, fading of painted surfaces or metal coating).

### Miscellaneous

- a) If repair of the defect or replacing the part is disproportionate, **RIEJU** shall be entitled to decide, at its sole discretion, whether to repair or replace the defective parts. Ownership over the replaced parts, if applicable, shall be held by **RIEJU**, with no other consideration. The dealer authorised by **RIEJU** whom has been entrusted to repair defects shall not be authorised to make binding statements on **RIEJU'S** behalf.
- b) If there is doubt as to whether there is a defect or a visual or material inspection is required, **RIEJU** reserves the right to require that the parts being claimed under the warranty be sent to it, or to request that a **RIEJU**



expert examine them. Any additional warranty obligations for replaced parts at no cost or for any services provided at no cost under this warranty shall be excluded. The warranty for replaced components during the warranty period shall end on the expiry date of the warranty period of the respective product.

c) If a defect cannot be repaired and its replacement is disproportionate for the manufacturer, the consumer under warranty shall be entitled to cancellation of the contract (payment of a compensation) or partial reimbursement of the purchase price (discount) instead of motorcycle repair.

d) The purchaser's warranty claims under the purchase-sale contract with the authorised dealer shall not be affected by this warranty. This warranty shall not affect the purchaser's additional contractual rights under the general business conditions of the authorised dealer. However, said additional rights may only be claimed with the authorised dealer.

e) If the purchaser resells the product during the warranty period, the terms and conditions of this warranty shall continue to exist under their current scope, such that rights to claim pursuant to this warranty under the terms and conditions governed by this document shall be transferred to the new owner of the motorcycle.







**RIEJU**

FOR EVERYDAY ADVENTURE